

Solenoid Valve Specifications and Dimensions: 2W025-040 Series

Valve Model	2W025	2W035	2W040
Valve Type	2 Way Normally Closed (NC)		
Action	Direct Acting		
Cv (Orifice)	0.23 (Orifice: 2.5mm)	0.5 (Orifice 3.5mm)	0.6 (Orifice 4mm)
Operating Pressure	Vacuum to 150 PSI		
Operating Temperature	Standard: NBR Seal: -10 to 80°C; Option: Viton Seal: -15 to 120°C		
Port Size (NPT)	1/4		3/8
Body Materials	Brass		
Seal Materials:	NBR (Options: Viton)		
Coil Protection Insulation Class	H Class IP65		
Coil Duty	100% ED		
Coil Power	20W		
Electrical Connections	DIN		
Service	Air, Liquid, Oil, Water		
<p>ALL Standard valves are supplied with CONTINUOUS DUTY COILS of the proper class of insulation for the service indicated on the valve. The coil temperature may become hot after being energized for extended periods, but it is normal. Smoke or burning odor indicates excessive coil temperature and should disconnect the power to the coil immediately.</p> <p>VOLTAGES: Standard: 12-24V DC and 24-110-220-230V/50-60 Hz AC. Voltage tolerances: +10% -5% for DC, +10%-15% for AC;</p> <p>SERVICE LIFE: The service life of the solenoid valve depends on the operating conditions such as pressure, temperature, type of medium and the voltage. Normally the STC solenoid valves are reliable for more than 5 million cycle</p>			

2W025-040 are DIRECT ACTING solenoid valves and do not require a minimum operating differential pressure. As shown below when the coil is energized (right diagram), it lifts the solenoid plunger, which normally rests on the valve seat and lifts it to open the main valve orifice. When the coil is de-energized (right diagram), the spring force the plunger return to the valve seat to close the valve orifice.

De-energized

Energized

2-Way, Direct Acting, Normally Closed

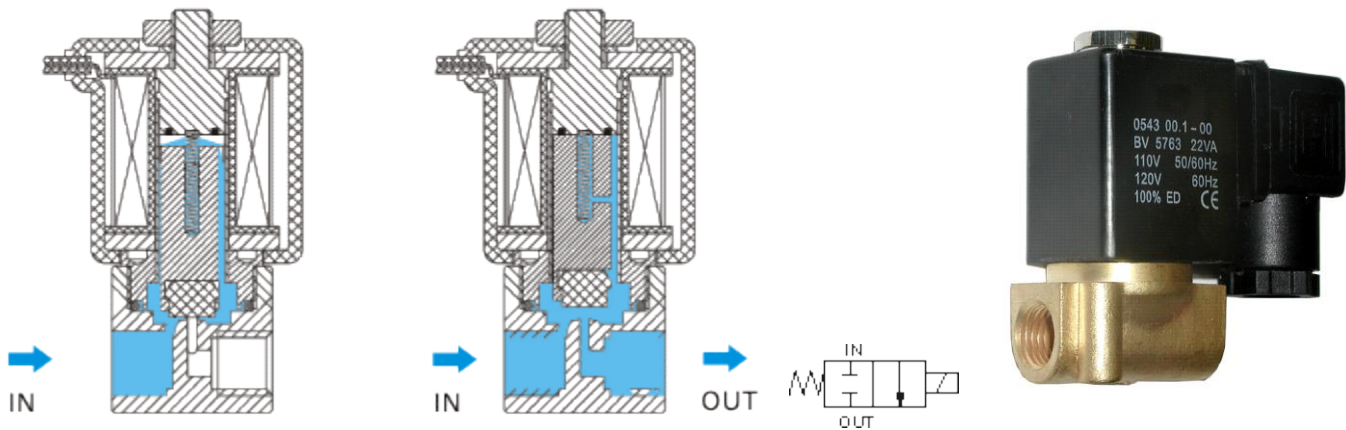

Electrical Coil Connections	
For DIN Coil	<p>To connect DIN coil:</p> <ol style="list-style-type: none"> 1. Remove the Philip screw from the plastic housing and unplug it from the DIN coil. 2. From the screw opening, push the terminal block out from the plastic housing. 3. Note the 1, 2 and ground markings on underside of DIN enclosure. 4. For DC DIN Coil, Connect 1 to Positive, 2 to Negative. 5. For AC DIN Coil, connect 1 to HOT wire, 2 to Neutral wire, and if required connect ground to ground wire.
For Grommet Coil	<p>To connect Grommet coil:</p> <ol style="list-style-type: none"> 1. For DC Coil, connect one of the two wires to Positive, and the other wire to Negative. 2. For AC Coil, connect one of the two wires to HOT wire, and the other wire to neutral wire.

MODEL: 2W025-1/4

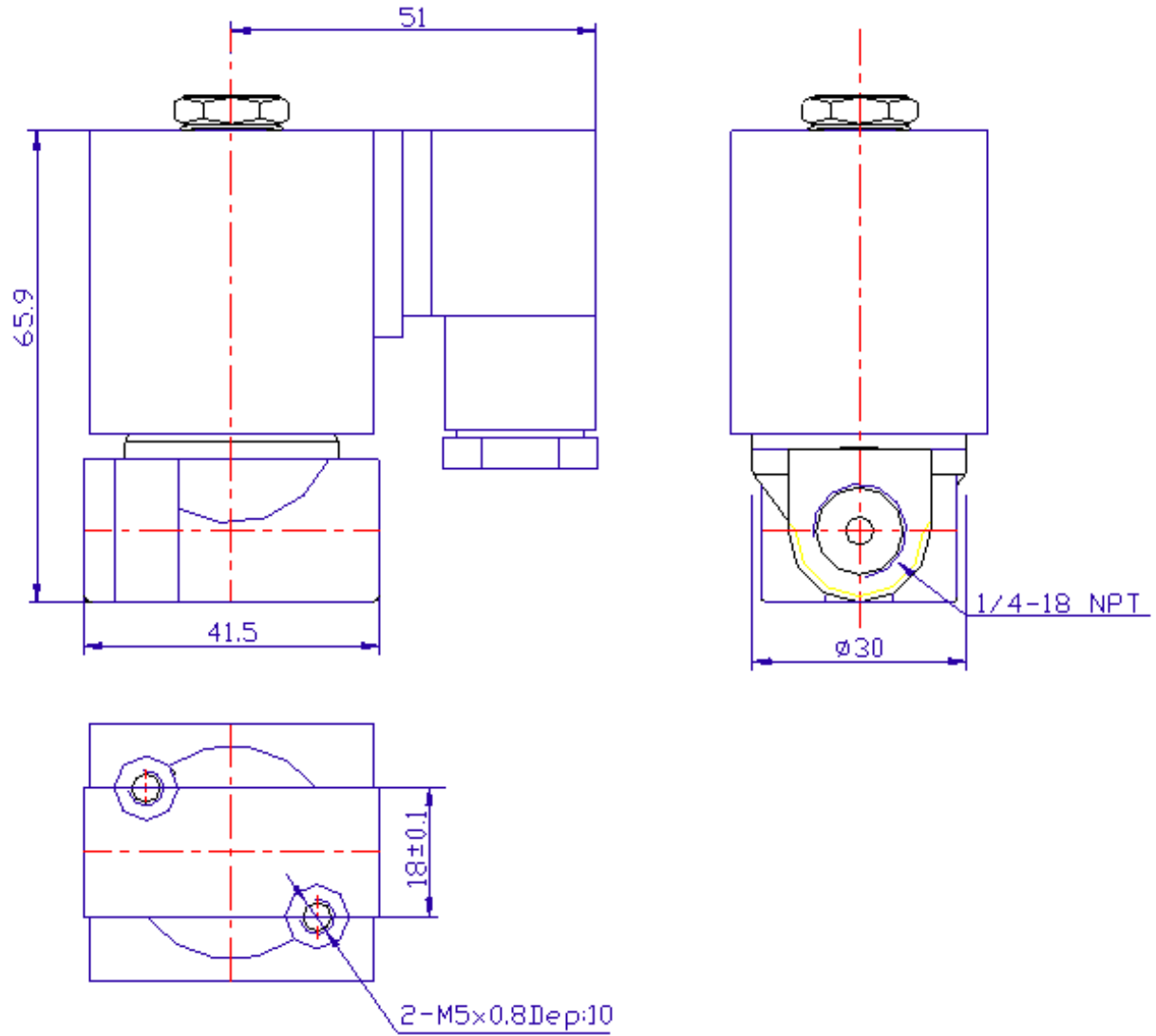

MODEL: 2W040-3/8

